



BS-9000

**Backsense[®]
CAN Radar Object Detection System**

Installation & Operating Guide

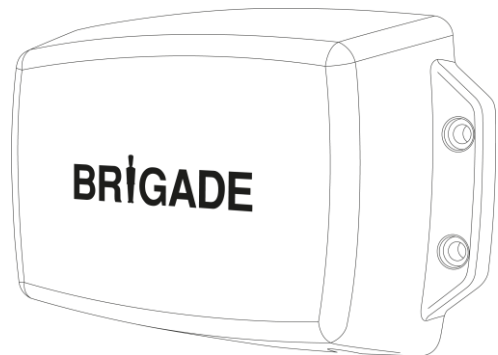

Table of Contents

1	Introduction	3
1.1	Detection Range	3
1.2	Object Detection Capability	3
2	Contents.....	6
2.1	Standard System Contents	6
2.2	Optional items (not included).....	6
3	Object Detection.....	7
3.1	Separate Object Detection	7
3.2	Detected Object Data.....	7
3.3	Detected Object Position Relative to Sensor	8
4	Hardware Installation.....	9
4.1	Recommended Network Layouts and Limitations	9
4.2	Good Network Arrangement.....	9
4.3	Bad Network Arrangement	10
4.4	Test Site	10
4.5	Sensor Mounting and Location.....	10
4.6	Cable	11
4.7	Electrical Connections.....	12
4.8	Power Input.....	12
4.9	Recommended Fuse Values	13
5	CAN Bus	14
5.1	Network Parameters	14
5.2	Keep Alive Message	14
5.3	CANbus Base ID.....	14
5.4	Base ID Configuration	15
5.5	Configuration Message Structure and Examples.....	16
5.6	Addressing Strategy for Detected Object and Generated Messages	16
5.7	Detection Message	16
5.8	Sensor Start-up Messages.....	17
6	System Host.....	18
6.1	Host Responsibilities.....	18
7	Brigade Backsense CAN Radar Test Tool.....	19
7.1	PC Interface for BS-9000	19
7.2	PC System Requirements.....	19
7.3	CANpro – BS-9000 Network connection cable	19
7.4	Software Installation.....	20
7.5	Backsense CAN Radar Test Tool.....	23
7.6	Backsense Configuration Tool.....	26
7.7	System Errors	33
8	Testing and Maintenance	34
8.1	Operator Instructions.....	34
8.2	Maintenance and Testing.....	34
9	Specifications	36
10	Mounting Dimensions	38
11	Disclaimer	39

1 Introduction

Brigade's Backsense® uses FMCW (Frequency Modulated Continuous Wave) radar system technology and is designed to detect people and objects in blind spots, significantly reducing collisions. Backsense® detects both stationary and moving objects and works effectively in harsh environments with poor visibility including darkness, smoke, fog and dust.

The Brigade BS-9000 radar sensor features an internal CAN interface for network connectivity, allowing the user to link up to 8 sensors and a network host on a single CAN bus, enabling monitoring of multiple detection areas around the vehicle.

Each Backsense® BS-9000 sensor is capable of detecting and reporting data for up to 8 objects enabling a fully featured system (consisting of 8 sensors) to detect and report up to 64 separate objects.

To ensure the Backsense® system performs to the best of its ability, it is imperative that installation and commissioning is carried out by competent, trained technicians. The installer is responsible for the fitness for purpose of the overall system and must adhere to relevant regulations and legislation.

Operators of the vehicle to which the Brigade Backsense® System is fitted must be made fully aware of how to interpret the system so they will not be distracted by or rely completely on it. Distraction can cause collisions.

The system is intended as an aid only. The operator must still concentrate on operating the vehicle, obeying traffic and local regulations and continuing to use his/her own training, senses and other vehicle aids, such as mirrors, as if the system were not in place. Nothing removes the responsibility of the operator to operate the vehicle in a proper and lawful manner.

1.1 Detection Range

Model Name	Detection Length		Detection Width		Nominal Tolerance	
	[m]	[ft]	[m]	[ft]	[m]	[ft]
BS-9000	0 – 30	0 – 98	0 – 10	0 – 33	±0.25	±1

1.2 Object Detection Capability

Warning

- **There is no detection of objects or part of an object closer than approx. 0.3m to the sensor.**
- Object detection **between approx. 0.3m to 1.3m from the sensor requires a minimum relative speed** of around 2km/h between the object and sensor. The same requirements apply for re-detection of objects after a stationary condition.
- Brigade Backsense® radar beam angle has a 120° horizontal angle out to the maximum designated width and symmetrically perpendicular to the sensor front surface. The vertical angle is 12°.
- All dimensions for detection of objects are nominal and vary significantly depending on many parameters. For more details, see section "1.2.2 Factors Influencing the Detection of Objects".
- An object will cause a detection data transmission in less than 0.5 seconds.

- After turning on power the system takes around 1 second to be active. There is no standby mode.

Notes:

- For distances below 1.3m (detection with relative speed only) or below 0.3m (no detection) the space covered in general by radar systems is very small. In this scenario, Backsense® may not be the most suitable solution and therefore Brigade recommends adding an additional or alternative detection system depending on the vehicle's application. For example, Brigade Backscan® based on ultrasonic sensing technology, offers superior detection at close ranges.
- Brigade Backsense® systems remain unaffected even when multiple sensors are operating in the same area or on the same vehicle. Close proximity and overlapping detection areas cause no adverse effect on Backsense's detection properties.

Tip: Brigade Backsense® detection is generally better when there is relative speed between the sensor and the objects and when the direction of approach is perpendicular to the sensor front face.

1.2.1 Detection Pattern

1.2.1.1 Horizontal Pattern

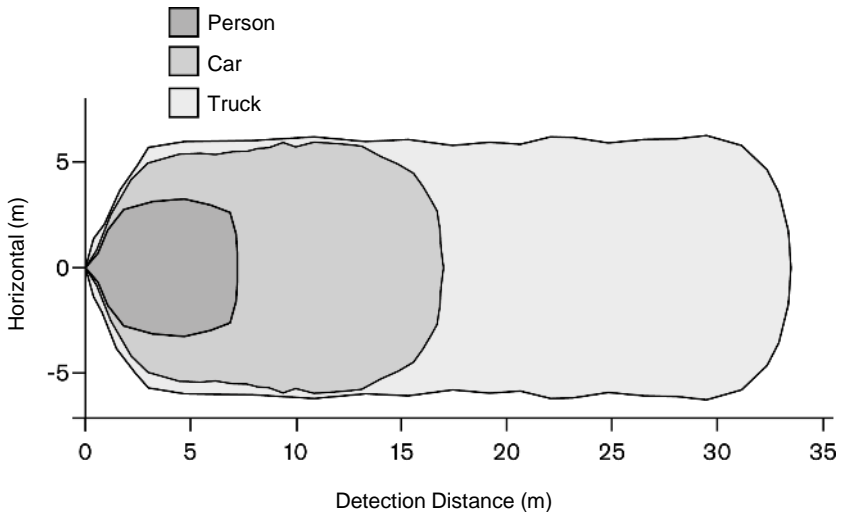

1.2.1.2 Vertical Detection Area

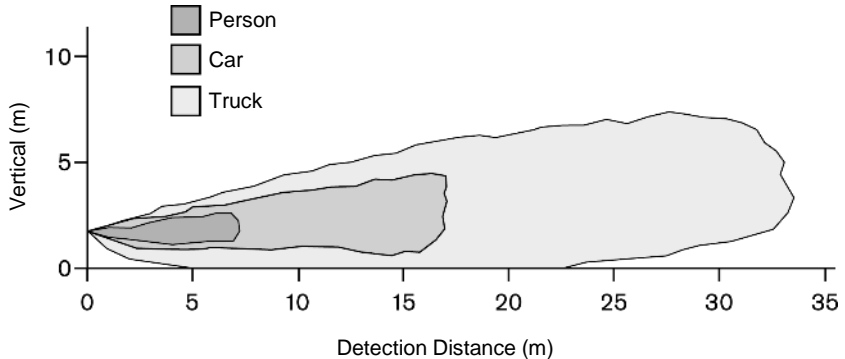

1.2.2 Factors Influencing the Detection of Objects

Brigade Backsense® shares in principle the advantages and limitations of all radar-based systems when compared to other sensing technologies. In general, it can reliably detect most objects in most environmental conditions such as dirt, dust, rain, snow, sun, fog, darkness, acoustic noise, mechanical vibration, electromagnetic noise or similar.

However, there are some occasions when an object could stay undetected. Radar works on the principle of line of sight and relies on some of the electromagnetic energy transmitted by the sensor being reflected back from the object to the sensor. If an object does not reflect enough electromagnetic energy back to the sensor it will not be detected.

In the case where there are multiple objects in the detection area at various distances and/or angles, the sensor will detect up to 8 of the closest objects (based on radius), which are the most important for collision avoidance.

The object properties, location and direction are key influences in determining if an object is detected or not. The influencing factors are listed below.

- **Size:** Larger surfaces are detected better than smaller surfaces. If there are small and large objects in the detection area, the smaller object might only register in Detection Zones closer to the sensor.
- **Material:** Metal is detected better than non-metal materials, e.g. wood, plastic.
- **Surface:** A smooth and solid surface is detected better than rough, uneven, porous, fragmented or liquid surfaces, e.g. bushes, brick work, gravel, water.
- **Shape:** A flat object is better detected than a complex shape. Variation in relative location and direction can influence detection significantly.
- **Angle:** An object facing directly towards the sensor (perpendicular, orientation head on to the sensor) is detected better than an object that is located towards the edges of the detection area or at an angle.
- **Distance:** An object closer to the sensor is better detected than one that it is further away.
- **Relative speed to sensor:** Detection is better if there is a relative speed between object and sensor.
- **Ground condition:** Objects on flat, mineral material ground are better detected than on rough or metal surfaces.
- **Environmental conditions:** Dense dust or very strong rain or snowfall will reduce the detection capability.

2 Contents

2.1 Standard System Contents

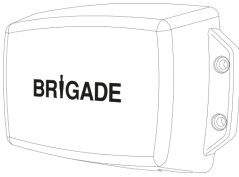

Sensor
BS-9000S



Sensor Fixing Kit
BS-FIX-01

2.2 Optional items (not included)



Extension Cables 2m, (6ft) 5m (16ft), 9m (29ft) or 25m (82ft)
BS-02DCX BS-05DCX or BS-09DCX
BS-25DCSX

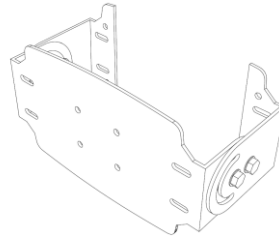

Adjustable Sensor Bracket
BKT-017

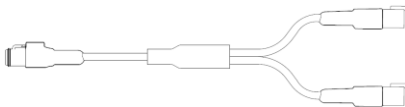

Network Y Cable
BS-00NYC

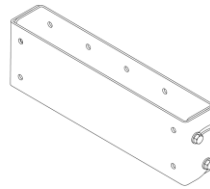

Low Profile Adjustable Sensor Bracket
BKT-018



Network Power Input Cable
BS-02PIC



120Ω Network Terminator
BS-00NT

3 Object Detection

3.1 Separate Object Detection

Each Backsense® BS-9000 sensor is capable of detecting and reporting data for up to 8 objects within the limitations detailed in section 1.2. In the event that there are more than 8 objects within the detection area of a particular sensor, only the closest 8 detections will be reported, (based on object radius from sensor)

3.2 Detected Object Data

The BS-9000 will transmit data for each detected object in separate CAN messages. The following detection data will be reported:

Data Definition	Minimum Value	Maximum Value	Description
Polar Radius	0.25m	30.25m	Line of sight distance between object and sensor front face.
Polar Angle	-60 ⁰ (Left)	+60 ⁰ (Right)	Angle between object and sensor front face. Position perpendicular to the sensor represents 0 ⁰ .
Co-ordinates X	0.25m	+30m	Object distance forward from front face of sensor.
Co-ordinates Y	-5m (left)	+5m (Right)	Object distance left or right of sensor position.
Relative Speed	-64KPH	+63.5KPH	Speed difference between sensor and object. Negative value indicates object approaching the sensor. Positive value indicates object leaving the sensor.
Reflected Signal Level	0dB	127dB	Power of reflected radar signal from object.
Object ID	0	7	Object identity. 0 represents closest object to sensor.
Object Appearance Status	0	1	Logic '1' indicates detection of new object. Logic '0' indicates detection of existing object.
Trigger Event	0	4	Similar to CANOpen requirements; this parameter identifies the reason for message transmission. 0 = Keep Alive, 1 = object detection, 2 = future use, 3 = future use.
Detection Flag	0	1	Logic '0' indicates object detection. Logic '1' indicates no object detection.

Further technical details of detection data are available in section 5.7.

3.3 Detected Object Position Relative to Sensor

The image below illustrates the relative position of detected objects with respect to the sensor's front face

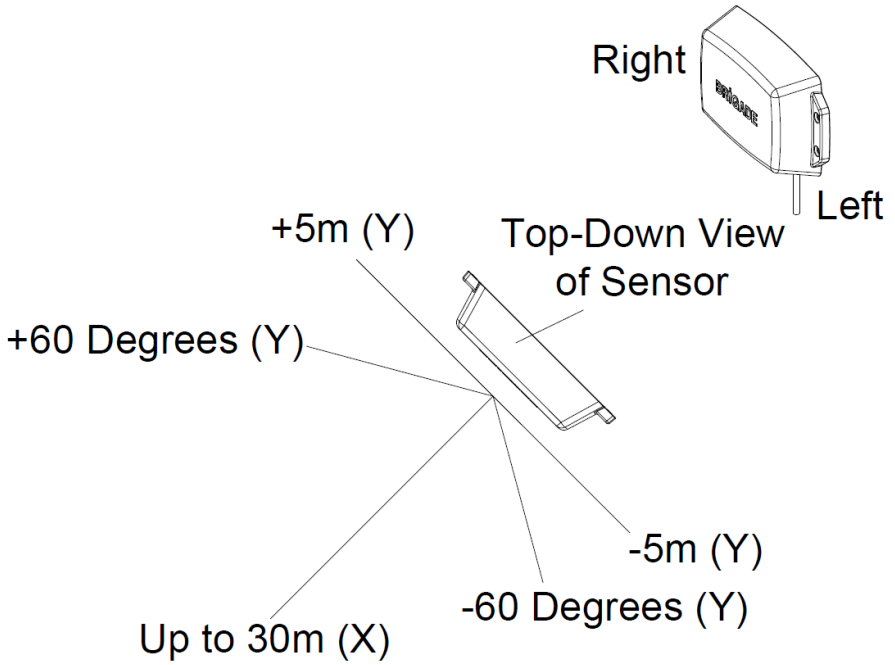

4 Hardware Installation

4.1 Recommended Network Layouts and Limitations

Backsense® BS-9000 Systems installation must adhere to a strict network topology to ensure reliable communications between all sensors and host.

The network topology must represent a bus featuring 120Ω termination at both ends. Sensors must be connected to the bus via Network Y-Cable only. The user must not install any extension cable between the sensor and the Y-Cable. Examples for good and bad network arrangements are show below:

4.2 Good Network Arrangement

Good Network Topology Includes:

- 120Ω Termination at both ends
- Bus Length limited to 30m between terminations
- Power input position balanced depending on the sensor's physical distribution on the bus. This should be optimised to minimise voltage drop over the cable for each sensor.
- No extension cables installed between the sensor and the Y-Cable. Only sensor tail cable to Y-Cable is allowed.

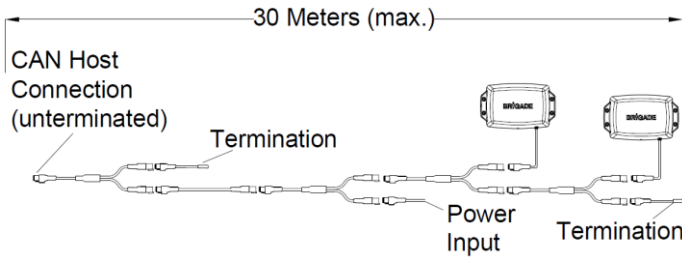

Example 1 (Good), host connection at end of bus

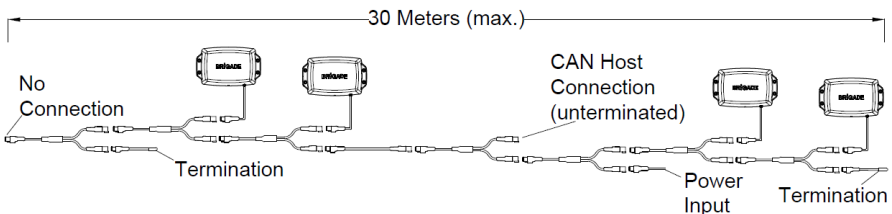

Example 2 (Good), host connection in middle of bus

4.3 Bad Network Arrangement

Bad Network Topology may include:

- Long bus length >30m.
- Non-bus configuration (e.g. star, mesh etc.).
- Power at one end only (resulting in possible voltage drop in cable).
- Termination missing at both ends of network.
- Omission of Network Terminator cable.
- Extension cable between sensor and Y-Cable.
- Connection to more than 8 sensors on single bus.
- Connection to other CAN nodes, (not shown below).

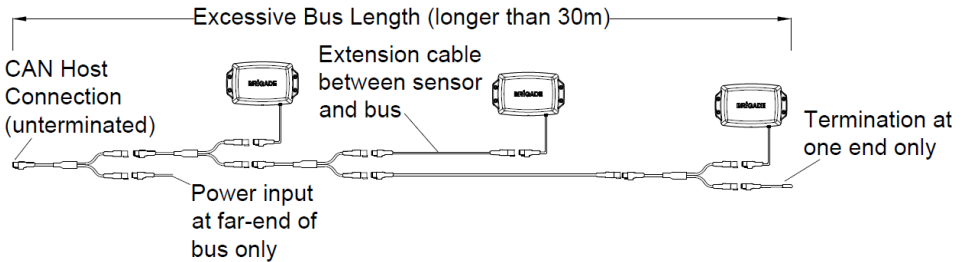

Example 3 (Bad), host connection at end of bus.

4.4 Test Site

The system test site should be relatively flat without excessive deviation and must be larger than the detection range of each sensor in the intended Backsense® system network. This will enable a basic setup, configuration and testing.

4.5 Sensor Mounting and Location

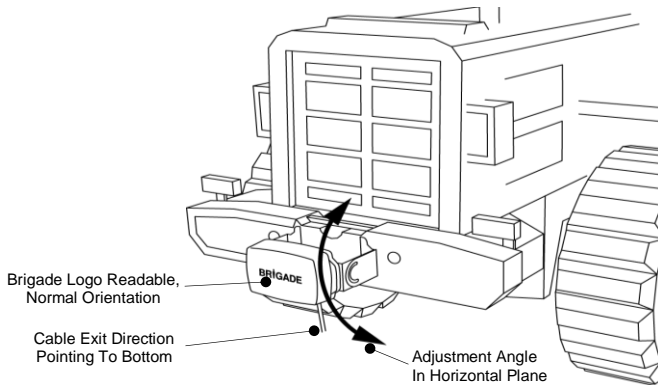

4.5.1 Sensor Direction

Each sensor should be mounted in an upright position with cable exit on the sensor pointing downwards. The Brigade logo on the front of the sensor should be in readable, normal orientation when standing in the required detection area, see image above. The front of the sensor should have line of sight to all areas where objects should be detected.

4.5.2 Sensor Fixing

Each unit is supplied with four M5x30mm screws and four M5 polymer locknuts for mounting purposes. The recommended torque is 6Nm or 50 inch/lbs.

4.5.3 Vehicle Overhang into Detection Area

The vehicle mounting locations should avoid detection of any overhang or furniture where possible. Such objects will cause false detections (for exceptions see section "1.2 Object Detection Capability", paragraph "Warning"). The detection area of the Brigade Backsense® radar beam has a 120° horizontal angle to the maximum designated width and a vertical angle of 12°, see section "1.2.1 Detection Pattern" for details.

In the event of unavoidable detection of vehicle body areas, the host system must ignore these detections.

4.5.4 Mounting Angle

Brigade recommends mounting the radar sensors on brackets (available from Brigade, see section 2.2), which can be adjusted for angle in the horizontal plane, enabling performance optimisation. See below for suggested vertical angle vs sensor installation height on the vehicle.

Depending on the vehicle, working environment and typical objects to be detected an adjustment of a few degrees around the suggested values can improve the detection performance or avoid false detection.

Installation height on vehicle (to sensor centre point)		Adjustment angle in upward direction from the horizontal plane
[m]	[in]	[°]
0.3m	12	9
0.5m	20	7
0.7m	28	5
0.9m	35	4
1.1m	43	3
1.3m	51	2
1.5m	59	0

4.6 Cable

Cables should be run in conduit and along suitable cable runs throughout the vehicle. A 24mm hole is required to pass the connectors through.

- Note:
- Allow a reasonable bending radius when folding excess cabling or for the routing of the cable.
 - Avoid tight bends close to the connectors.
 - Avoid pulling on the connector.
 - Ensure all cables are fitted into suitable protective conduit
 - Ensure cabling and connectors are fitted away from sources of excess heat, vibration, movement and water or dirt.

4.7 Electrical Connections

Refer to the vehicle manufacturer or bodybuilder guidelines for installation procedures and connectivity in all applications. The sensor pinout is shown in the table below and connector details given in section 9:

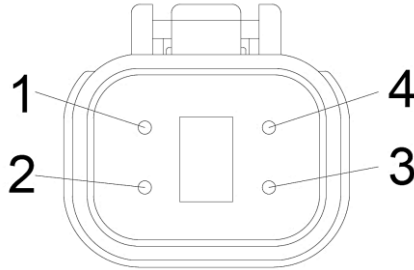

Deutsch Pin	Signal Name	Brigade Wire Colour
1	Ground	Brown
2	CAN High	Green
3	Positive (+12/+24V)	Yellow
4	CAN Low	Blue

4.8 Power Input

Power must be applied to the BS-9000 sensor network via a dedicated Brigade power cable. Only one power input to the system is permitted and must be suitably positioned within the network to ensure that loading from all sensors is balanced and excessive voltage drops are avoided.

The network must be adequately powered under all operating conditions. The installer must verify that any volt drop throughout the network does not cause the supply at the sensor to drop below the minimum recommended value during operation.

A single fuse must be installed per network. Multiple fuses are not permitted. The table in section 4.9 provides power consumption data and fusing recommendations for various network sizes under a range of supply voltages.

4.9 Recommended Fuse Values

Supply Voltage	Network Size (Number of Sensors)	Power Consumption	Steady State Current	Inrush Current	Recommended Fuse Value
12VDC	1	3.6W	0.31A	<0.85A, <20mSec	1A
	2	7.2W	0.62A		
	3	10.8W	0.93A		2A
	4	14.4W	1.24A		
	5	18W	1.55A		
	6	21.6W	1.86A		3A
	7	25.2W	2.17A		
	8	28.8W	2.48A		
24VDC	1	4.1W	0.17A	<0.45A, <20mSec	1A
	2	8.2W	0.34A		
	3	12.3W	0.51A		
	4	16.4W	0.68A		2A
	5	20.5W	0.85A		
	6	24.6W	1.02A		
	7	28.7W	1.19		
	8	32.8W	1.36		

5 CAN Bus

5.1 Network Parameters

The BS-9000 system must operate on an independent CAN bus with no other connections apart from power, terminations and typically one customer-supplied host.

CAN communications parameters from the sensor network are detailed below:

- Complies with CAN 2.0A Base Frame Format (11-bit Identifier)
- Programmable ID range per sensor
- Individual CAN ID for each detected object
- 500Kbits/second Baud Rate (Non-Configurable)
- Maximum of 8 sensors connected to the bus at any time
- Keep Alive message transmitted by sensors when no objects are detected
- Refresh Rate of ~21mSec per detected object message or Keep Alive message
- Intel Standard message format

5.2 Keep Alive Message

The Keep Alive message function provides a regular CAN message from each sensor when there are no objects detected by that sensor, or when the sensor has not been re-configured from the default CAN ID (detailed in section 5.3). The Keep Alive message may be used by the host system to verify that the radar is operational and working correctly during periods of no object detection.

5.3 CANbus Base ID

All BS-9000 sensors are shipped from Brigade with a pre-set Base ID of 0x390. Messages with this ID value do not contain any detection data but do provide a Keep Alive message to the host.

The installer must alter the 0x390 Base ID at system configuration and ensure that each BS-9000 sensor within a network is configured with a different Base ID. Instructions for altering sensor Base ID values are detailed in section 5.4.

The range of permissible Base ID values is given in the table below:

Sensor ID:	1	2	3	4	5	6	7	8
Base ID:	0x310	0x320	0x330	0x340	0x350	0x360	0x370	0x380

It is not permitted to connect sensors together that have the same Base ID. Therefore, during system configuration, the installer must ensure that each sensor's Base ID is programmed whilst only that sensor is connected to the host

5.4 Base ID Configuration

Systems installers may configure sensor base ID values using their own host system, or by use of the Brigade Test tool detailed in section 7. Each BS-9000 sensor within a network must be configured with an individual Base ID. The method for Base ID configuration is simple and involves sending a single configuration message to each individual sensor in the CAN network, using a specific "Configuration ID" for that sensor. The procedure is as follows:

1. Connect one unconfigured sensor (with default Base ID 0x390, which is the default sensor number 0x09) to the network. There must be no other sensors connected to the network during configuration.
2. Apply power to network.
3. Send configuration message (containing the desired sensor number) from host to connected sensor using the connected sensors configuration ID.
4. Disconnect and reconnect power from sensor or network.
5. Monitor the CAN bus and verify that the Base ID for the sensor under configuration has now changed from 0x390 to the Base ID configured in step 3.
6. Repeat from step 1 for next sensor to be configured

The tables below detail the various ID values used in the BS-9000 system.

Current Sensor ID values (Before Configuration)
Base ID and corresponding Configuration ID to be used

Current Base ID	Configuration ID to be used
0x310	0x150
0x320	0x151
0x330	0x152
0x340	0x153
0x350	0x154
0x360	0x155
0x370	0x156
0x380	0x157
0x390	0x158

Resulting Sensor ID values (After Configuration)
Desired Sensor Number and corresponding desired Base ID

Desired (target) Sensor Number	Desired (target) Base ID
0x01	0x310
0x02	0x320
0x03	0x330
0x04	0x340
0x05	0x350
0x06	0x360
0x07	0x370
0x08	0x380
0x09	0x390

5.5 Configuration Message Structure and Examples

Configuration Message Structure

11- Bit CAN ID	Data Byte 0	Data Byte 1	Data Byte 2	Data Byte 3	Data Byte 4	Data Byte 5	Data Byte 6	Data Byte 7
Current Sensor Configuration ID to be used	Sensor Number for desired (target) Base ID	Fixed value 0x00	Fixed value 0x00	Fixed value 0x00	Fixed value 0x00	Fixed value 0x00	Fixed value 0x00	Fixed value 0xFF

Configuration Message Example, Base ID change from 0x390 to 0x310

11- Bit CAN ID	Data Byte 0	Data Byte 1	Data Byte 2	Data Byte 3	Data Byte 4	Data Byte 5	Data Byte 6	Data Byte 7
0x158	0x01	0x00	0x00	0x00	0x00	0x00	0x00	0xFF

Configuration Message Example, Base ID change from 0x320 to 0x330

11- Bit CAN ID	Data Byte 0	Data Byte 1	Data Byte 2	Data Byte 3	Data Byte 4	Data Byte 5	Data Byte 6	Data Byte 7
0x151	0x03	0x00	0x00	0x00	0x00	0x00	0x00	0xFF

5.6 Addressing Strategy for Detected Object and Generated Messages

Each BS-9000 sensor is capable of detecting and reporting data for up to 8 closest objects. Each detected object has an individual message ID whose value is dependent on the proximity of the detected object to the sensor.

Object Proximity to Sensor	Sensor ID Number							
	0x01	0x02	0x03	0x04	0x05	0x06	0x07	0x08
Closest Object	0x310	0x320	0x330	0x340	0x350	0x360	0x370	0x380
2 nd Closest Object	0x311	0x321	0x331	0x341	0x351	0x361	0x371	0x381
3 rd Closest Object	0x312	0x322	0x332	0x342	0x352	0x362	0x372	0x382
4 th Closest Object	0x313	0x323	0x333	0x343	0x353	0x363	0x373	0x383
5 th Closest Object	0x314	0x324	0x334	0x344	0x354	0x364	0x374	0x384
6 th Closest Object	0x315	0x325	0x335	0x345	0x355	0x365	0x375	0x385
7 th Closest Object	0x316	0x326	0x336	0x346	0x356	0x366	0x376	0x386
8 th Closest Object	0x317	0x327	0x337	0x347	0x357	0x367	0x377	0x387

5.7 Detection Message

Detection data for each detected object (per sensor) is reported in a single CAN message from the sensor with a message as detailed in section 3.2. Detection location data, relative speed, reflected power level and various detection flags are contained in individual bytes for ease of processing.

The message structure for the data field is detailed in the table below:

Detection Data	Data Field Start		Data Length	Data Offset	Message Resolution	Physical Value		Byte Value	
	Byte	Bit	(No.Bits)			Min	Max	Min	Max
Polar Radius	0	0	8	0	0.25m	0m	30.25m	0x00	0x79
Polar Angle	1	0	8	-128	1 ⁰	-60 ⁰	+60 ⁰	0x44	0xBC
Co-ordinates X	2	0	8	0	0.25m	0m	+30m	0x00	0x78
Co-ordinates Y	3	0	8	-128	0.25m	-5	+5	0x6C	0x94
Relative Speed	4	0	8	-128	0.5KPH	-64KPH	+63.5KPH	0x00	0xFF
Signal Power (dB)	5	0	8	0	1	0	127	0x00	0x7F
Object ID	6	5	3	0	1	0	7	n/a	n/a
Object Appearance Status	6	4	1	0	n/a	0	1	n/a	n/a
Trigger Event	6	1	2	0	1	0	3	n/a	n/a
Detection Flag	7	0	1	0	1	0	1	0x00	0x01

5.8 Sensor Start-up Messages

Each sensor will transmit various messages to the host upon power up. These messages may be used by the host to confirm that the particular sensor in the network has correctly started and is operational.

The transmission of the start-up messages is sufficient to verify that the sensor is operational. Start-up time (from power-on to completion of start-up messages) is detailed in section 9. The content of the start-up message has no functional use for the normal operation of the sensor and provide no information to the user.

The table below details start-up message vs sensor Base ID

	Sensor ID Number								
	0x01	0x02	0x03	0x04	0x05	0x06	0x07	0x08	0x09
Base ID	0x310	0x320	0x330	0x340	0x350	0x360	0x370	0x380	0x390
Start-up Message 1	0x100	0x100	0x100	0x100	0x100	0x100	0x100	0x100	0x100
Start-up Message 2	0x101	0x101	0x101	0x101	0x101	0x101	0x101	0x101	0x101
Start-up Message 3	0x101	0x102	0x103	0x104	0x105	0x106	0x107	0x108	0x109
Start-up Message 4	0x700	0x701	0x702	0x703	0x704	0x705	0x706	0x707	0x708

6 System Host

6.1 Host Responsibilities

BS-9000 systems require connection to a customer-supplied host to receive and utilise object detection messages from the sensor via CAN bus. The host system is responsible for interpreting the detection data detailed in section 5.7 and applying any logic, conditioning, filtering, activation or blind zone settings (e.g. ignoring certain detection under pre-determined conditions) that may be required in the application of the system. These features are not provided by the BS-9000 and detection data output from the sensor is not configurable.

7 Brigade Backsense CAN Radar Test Tool

7.1 PC Interface for BS-9000

As detailed in section 5, the Brigade BS-9000 radar sensors use CAN for all communications to the host system, including configuration and test activities.

In order for a user to configure and test the system using Brigade's software applications they must first obtain a CANpro USB Interface from the Softing company and install drivers for this interface on their test PC. The interface is not available from Brigade but may be purchased from Softing or their distributors by searching the website at www.softing.com

An image of the CANpro USB Interface is shown below. Note that although other CAN – PC interfaces will connect to the BS-9000 network, only the CANpro USB will work correctly with the Brigade Backsense CAN Radar Test Tool.



7.2 PC System Requirements

The Brigade Backsense CAN Radar Test Tool requires a PC with a USB 2.0 Type-A connector for connection to the CANpro USB interface. A USB cable with USB standard type A plug to B plug should be used and is included with the CANpro USB Interface. The Backsense CAN Radar Test Tool is compatible with Microsoft Windows 7 & 10 (32-bit or 64-bit version) operating systems.

7.3 CANpro – BS-9000 Network connection cable

Users will require a cable for connection between CANpro interface and BS-9000 sensor network. This cable is not available from Brigade and must be provided by the user. Pinout details are given in the table below. Note that the CANpro interface does not include termination and therefore Brigade Network Terminators will be required in this instance.

CANpro 9-way D-Type Pin Number	Deutsch 4-way Radar Connector	Signal Name
2	4	CAN LOW
7	2	CAN HIGH

7.4 Software Installation

7.4.1 Softing CAN Drivers and Software installation

Once the driver installation file has been downloaded from www.softing.com it should be installed as per standard practice. Screen views of the process are shown below (Note: Layout may vary depending on version).



Step 1 – Initial installation window

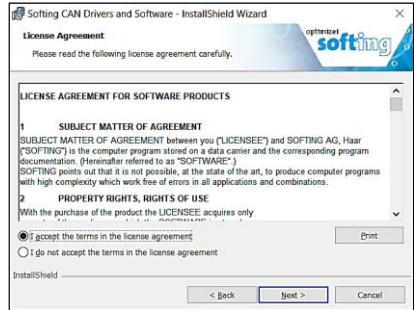

Step 2 – License agreement

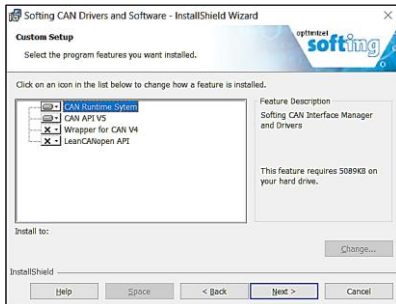

Step 3 – Feature selection



Step 4 – Feature confirmation



Step 5 – Installation in progress



Step 6 – Installation complete

The application can now be launched from the Start Menu under the heading Softing CAN.

7.4.2 Softing CAN Drivers and Software configuration

Once the setup has been completed, the Softing CAN Interface Manager should be launched. Once the interface is connected, it is automatically detected and configured.

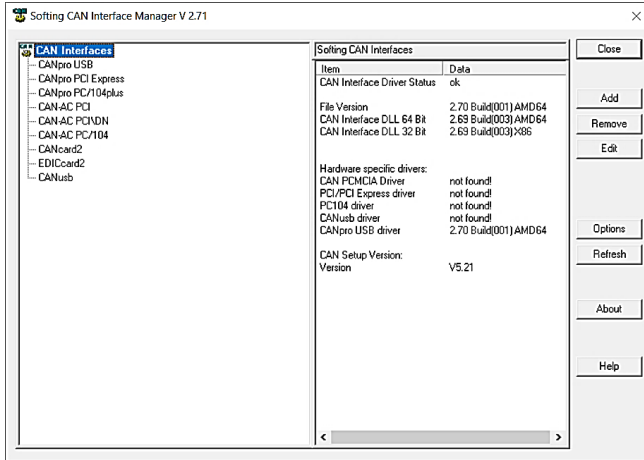

Before connection to the PC

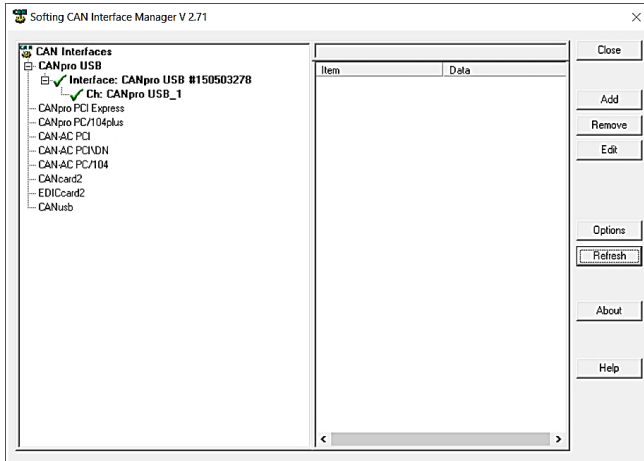

After connection to the PC with successful detection

Once completed, the Backsense CAN Radar Test Tool can be installed, without this application installed the Backsense CAN Radar Test Tool will suffer significant errors.

7.4.3 Backsense CAN Radar Test Tool installation

Once the driver installation file has been downloaded from www.brigade-electronics.com it should be installed as per standard practice. Screen views of the process are shown below (Note: Layout may vary depending on version).

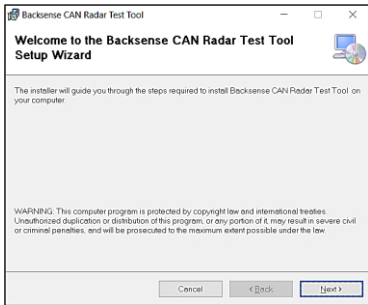

Step 1 – Initial installation window

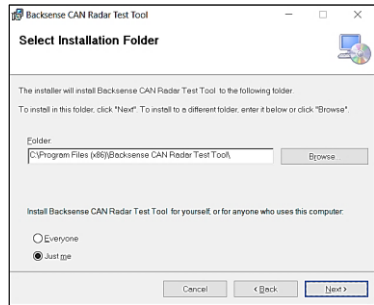

Step 2 – Installation location

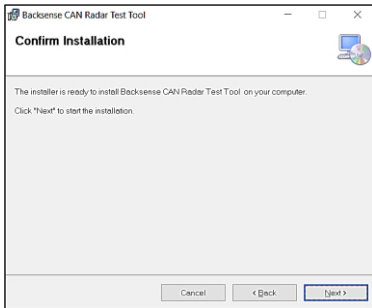

Step 3 – Installation confirmation

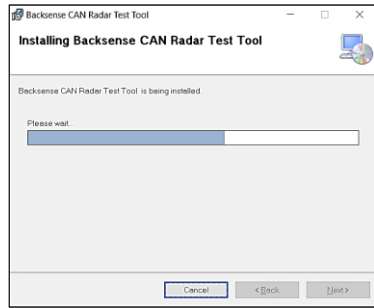

Step 4 – Installation in progress

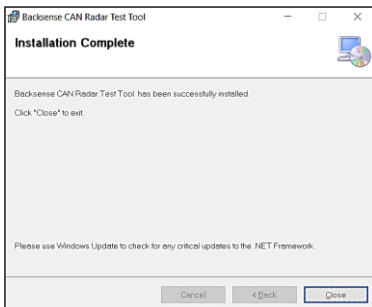

Step 5 – Installation complete

The application can now be launched from the Start Menu under the heading Backsense CAN Radar Test Tool.

7.5 Backsense CAN Radar Test Tool

The Brigade test tool is a windows application that enables users to view all physical detection data from the radar system in real time.

The test tool consists of a main Graphic & Control Window displaying a top-down view of detected objects for one selected sensor as well as a sub window for that sensor's detection data and another sub window displaying detected object positions for all sensors in the network. The Test Tool does not provide any CAN data from the sensor network however the Configuration Tool detailed in section 7.6 enables the user to view live CAN data and configure the Base ID for individual sensors. Each part of the test tool is explained in detail in the following sections.

7.5.1 Graphic & Control Window

The graphic and control window feature a menu bar with the following menus and options:

- File
 - Exit Application
- View
 - Backsense Detection Table – Opens in new sub window.
 - Backsense Network Summary Table – Opens in new sub window.
- Select Sensor – Change sensor selection for top-down detection view and Backsense Detection Table from below list:
 - Sensor ID 0x310.
 - Sensor ID 0x320.
 - Sensor ID 0x330.
 - Sensor ID 0x340.
 - Sensor ID 0x350.
 - Sensor ID 0x360.
 - Sensor ID 0x370.
 - Sensor ID 0x380.
 - Sensor ID 0x390.
 - Refresh – Refreshes the above list of connected sensors.
- Tools
 - Configuration Tool – Opens in new sub window.
- About
 - About Radar Test Tool.

The centre of the Graphic and Control Window displays a 2m grid representing the 30m long, 10m wide detection area for one BS-9000 sensor. A red filled circle at the bottom middle position of the grid represents the sensor location whilst purple triangle hachings either side of the sensor location represent the area in which objects cannot be detected due to the 120° detection angle.

During operation, detected objects are displayed as small green filled squares within the 30m x 10m detection area. The approximate position of the detected objects may be estimated by referencing their position with respect to the 2m grid lines. Note that the size of all green squares are constant and do not vary according to object size or detection data values.

A Pause/Run button is provided for the user to freeze live detection information on the screen. Note that the user may select which sensor they would like to view from the Select Sensor menu at the top of the screen. By default, the sensor with lowest base ID value is selected. An example of the Graphic and Control Window is shown on the following page.

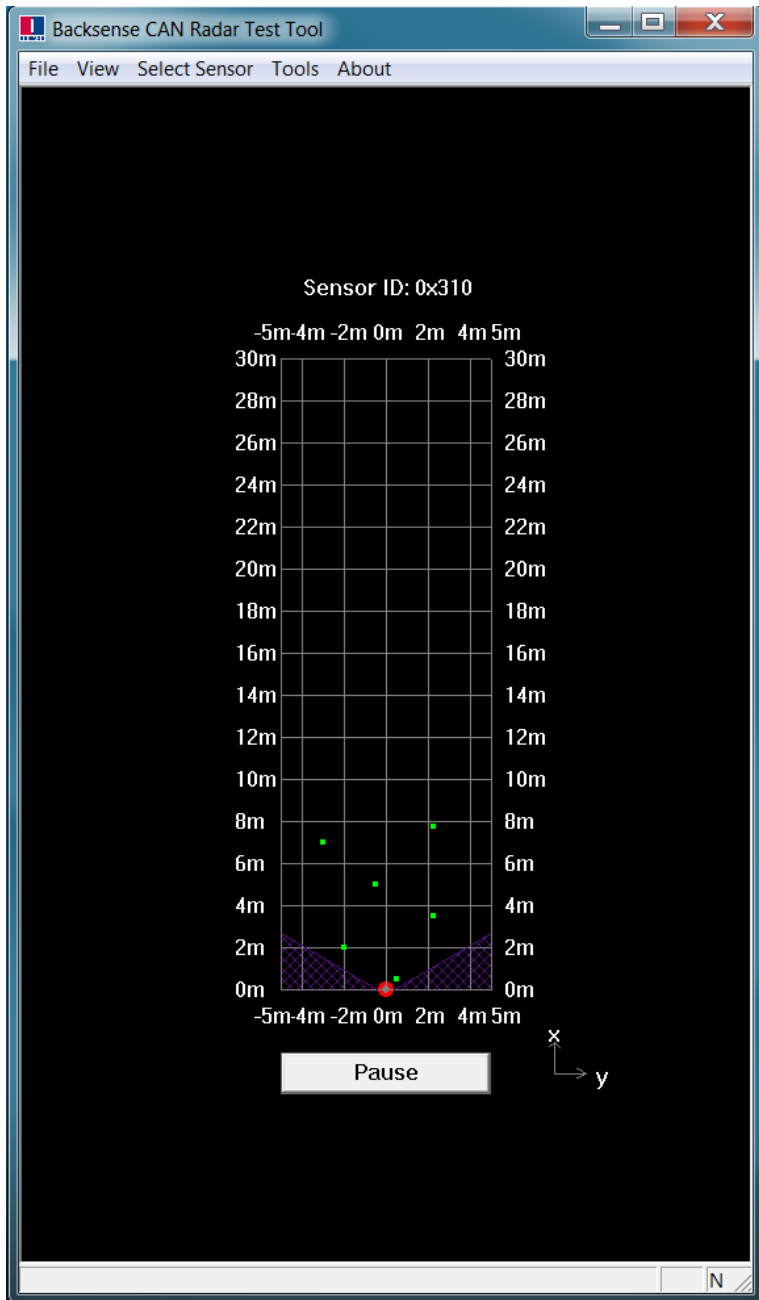

Graphic and Control Window displaying six detected objects for sensor 1 (CAN ID 0x310).

7.5.2 Backsense Detection Table

The Backsense Detection Table is a floating sub window of the Graphic and Control window which displays numerical values for all detection data of up to 8 closest objects detected by the selected sensor.

There is no user interaction available for the Backsense Detection Table. As with the detection grid of the Graphic and Control, the sensor with lowest base ID value is selected by default. An example from the Detection Table is shown below:

Sensor Parameter	Unit	0x310	0x311	0x312	0x313	0x314	0x315	0x316	0x317
Object Radius	m	0.50	3.00	4.25	5.00	7.50	8.00		
Object Angle	Deg	30	-45	30	-5	-20	15		
X Coordinate	m	0.50	2.00	3.50	5.00	7.00	7.75		
Y Coordinate	m	0.50	-2.00	2.25	-0.50	-3.00	2.25		
Object Relative Speed	KPH	1	1	1	1	0	1		
Object Signal Level	dB	59	57	44	47	50	41		
Object Appearance Status	n/a	0	0	0	0	0	0		
Trigger Event	n/a	1	1	1	1	1	1		
Detection Flag	n/a	0	0	0	0	0	0		

Backsense Detection Table displaying detection data for six objects from Sensor ID 0x310.

7.5.3 Backsense Network Summary Table

The Backsense Network Summary Table is a floating sub window of the graphic and control window which displays X, Y co-ordinates for up to 8 detected objects of up to 8 connected sensors as per the maximum capability of the system. There is no user interaction available for the Backsense Network Summary Table. As with the detection grid of the Graphic and Control, the sensor with lowest base ID value is selected by default. An example from the Detection Table is shown below:

CAN ID X, Y	Unit	0x3X0	0x3X1	0x3X2	0x3X3	0x3X4	0x3X5	0x3X6	0x3X7
0x310_X	m	0.50	2.00	3.50	5.00	7.00	7.75		
0x310_Y	m	0.50	-2.00	2.25	-0.50	-3.00	2.25		
0x320_X	m								
0x320_Y	m								
0x330_X	m								
0x330_Y	m								
0x340_X	m								
0x340_Y	m								
0x350_X	m								
0x350_Y	m								
0x360_X	m								
0x360_Y	m								
0x370_X	m								
0x370_Y	m								
0x380_X	m								
0x380_Y	m								

Backsense Network Summary Table displaying detection data for six objects from Sensor ID 0x01

7.6 Backsense Configuration Tool

The Backsense Configuration Tool is a command line type application that enables the user to perform the following functions within the BS-9000 system:

- Alter CAN ID of each sensor within the permitted range.
- View live CAN data from the entire network.

7.6.1 The Backsense Configuration Tool may be launched from the “Tools” menu within the Backsense CAN Radar Test Tool, as shown below:

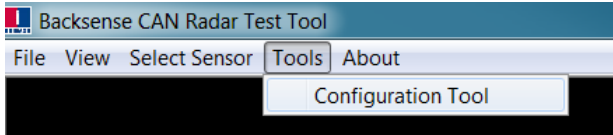

7.6.2 Depending on PC security settings, the following warning may be seen. The user must select “Run” to proceed to the application:

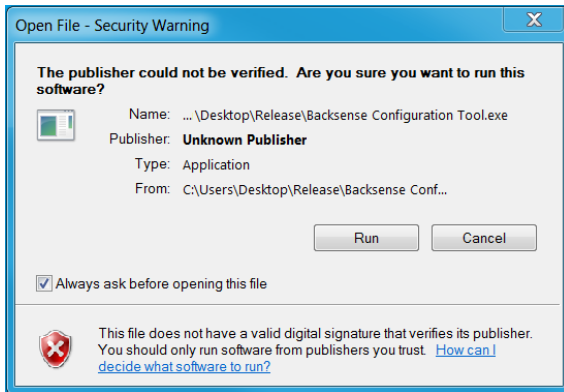

7.6.3 The launch screen of the Backsense Configuration Tool will appear as below. The connected CANpro interface is identified by serial number.

The user must press Return on the keyboard to continue:

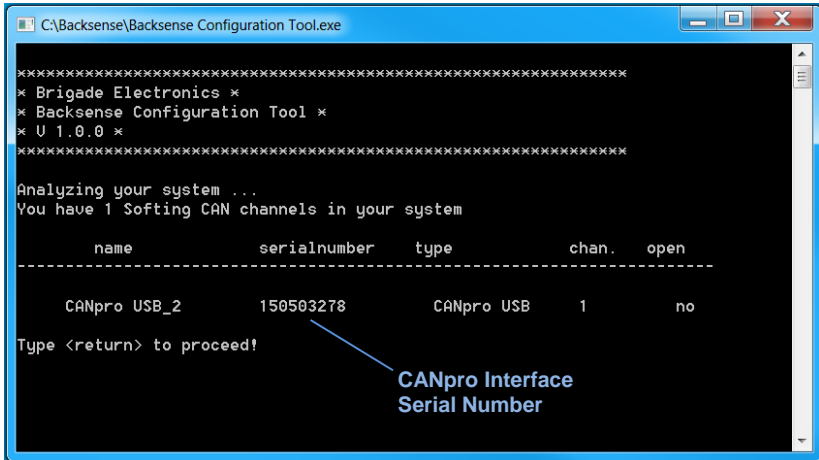

7.6.4 The Initialisation screen of the Backsense Configuration Tool will appear as below. Command options are displayed on the screen:

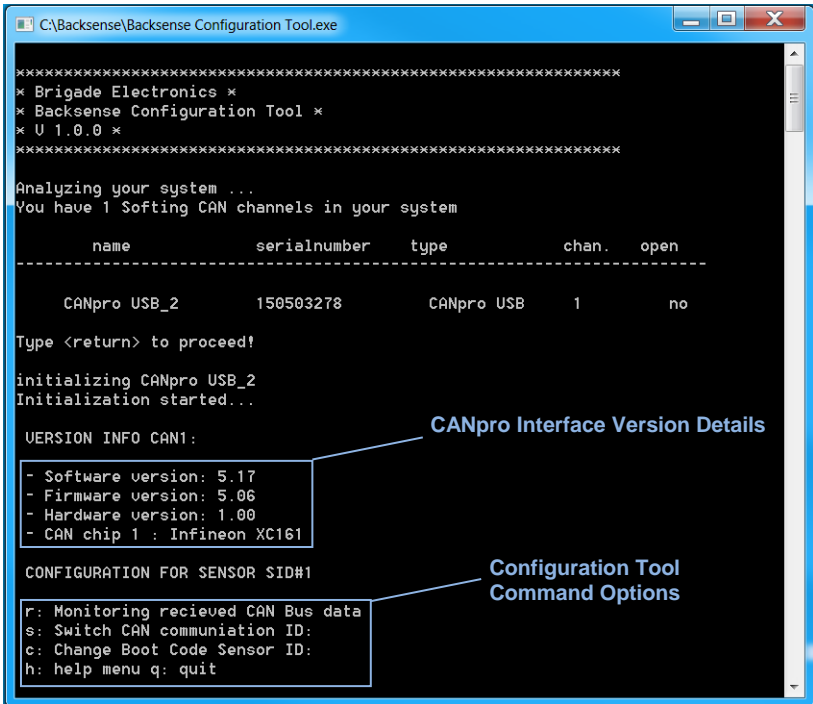

The Configuration Tool Command Options are as follows:

- r
 - Monitor CAN Bus Data – Allows the user to view all CAN data that appears on the bus.
- Space Bar
 - Pause live view of CAN Bus Data.
- s
 - Switch CAN ID for connected sensor – Allows the user to select the sensor ID number that is to be re-configured.
- c
 - Change Boot Code Sensor ID – User must select the desired target sensor ID number that is to be configured for the connected sensor.
- h
 - Display help menu – Configuration Tool Command Options will be re-displayed.
- q
 - Exit Configuration Tool application.

7.6.5 The user may start (or re-start) monitoring of live CAN data from the sensor (or entire Backsense network) by pressing the “R” key on the keyboard. Spacebar may be used to pause live CAN data.

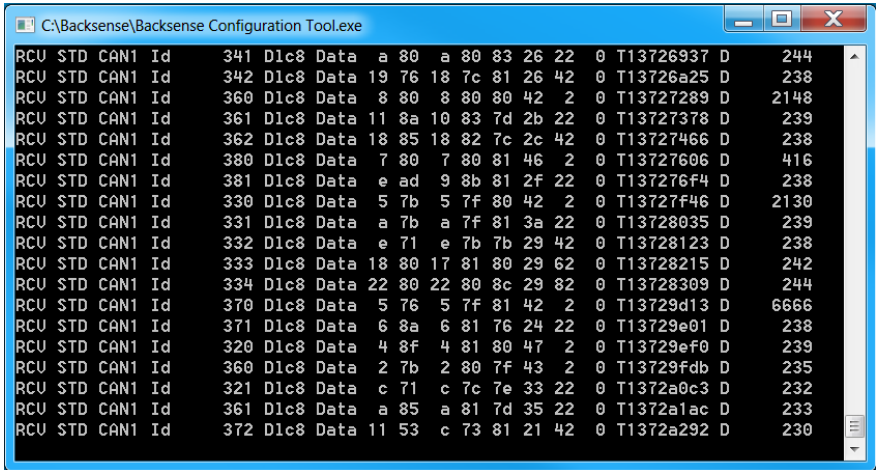

7.6.6 The description for Configuration Tool data is as illustrated below:

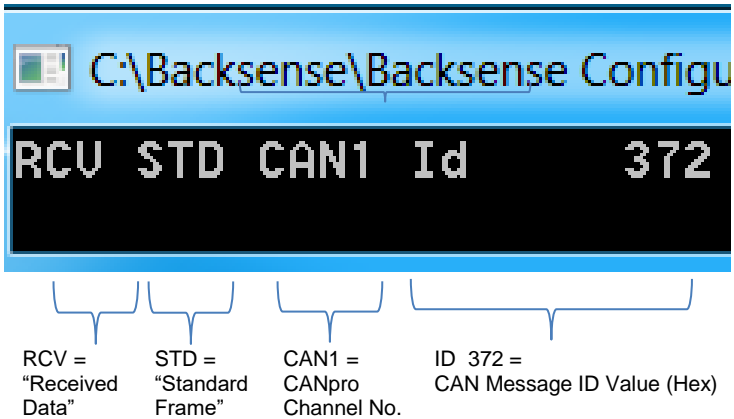

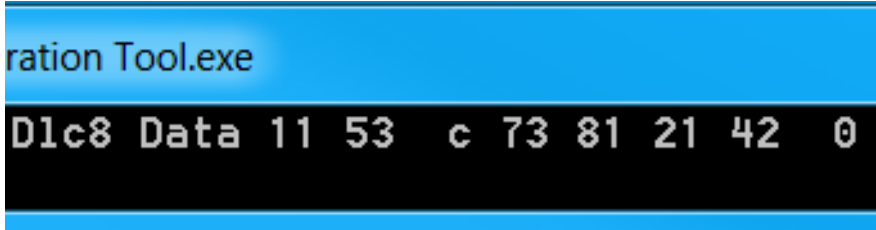

DLC8 = Data Length Code is 8 Bytes

Data XX XX XX XX XX XX XX XX= Detection Data in Hex format from sensor



T 1372a292 = Timestamp from launch of CAN driver (Hex uSec)

D 230 = Delta time since previous message (Dec uSec)

7.6.7 Pressing the “S” key on the keyboard will enter sensor ID configuration function as shown below:

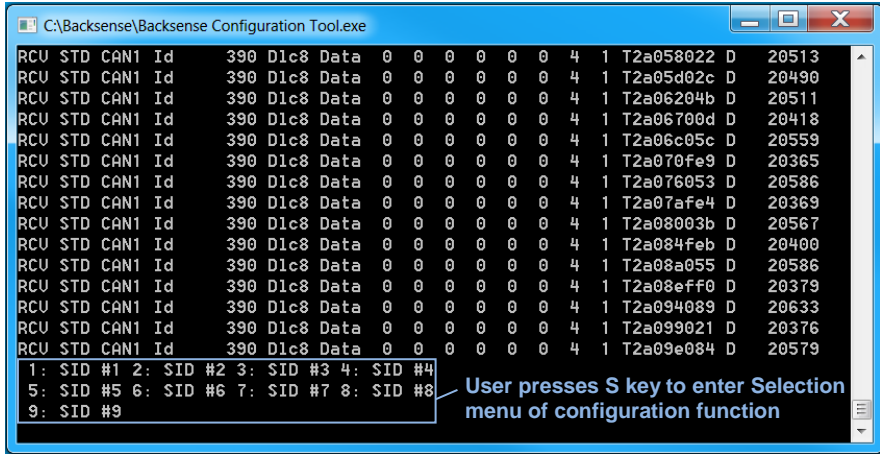

7.6.8 The user must select the sensor to be configured by pressing the number of that sensor on the keyboard. In the example below, only one sensor with Sensor ID 0x09 is connected, (as identified by “390” CAN data). In this instance the user will press “9” on the keyboard.

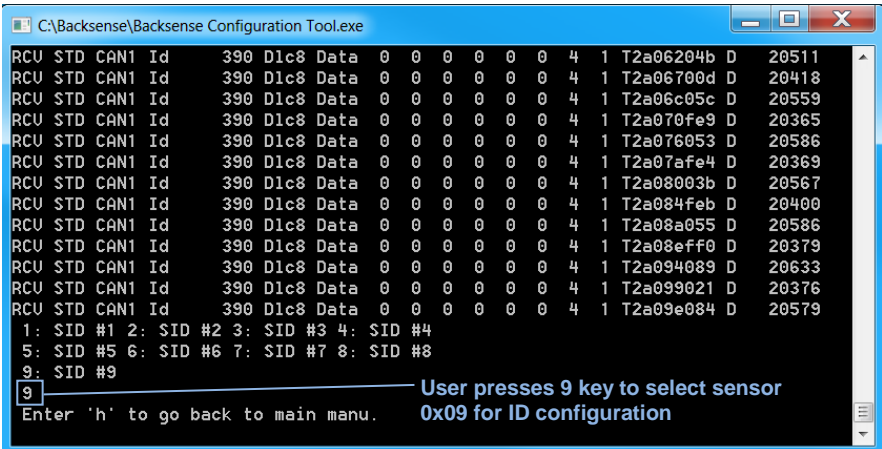

7.6.9 To re-configure the sensor ID, the user must press “C” on the keyboard as below:

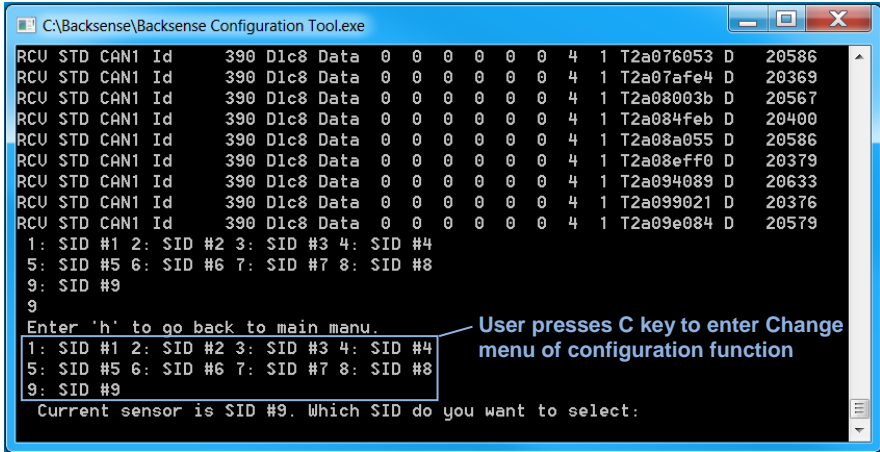

1

7.6.10 The user must select the number for the desired sensor ID. In the example below, the desired ID is 1 therefore the user presses “1” on the keyboard

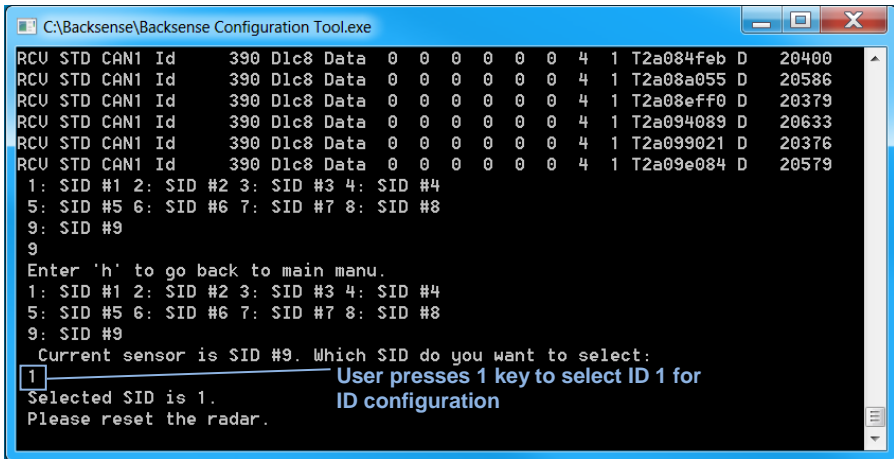

7.6.11 Now reset the radar (power cycle).

7.6.12 The user may check for correct ID change by monitor live CAN data from the sensor
Pressing the “r” key on the keyboard will start monitoring.

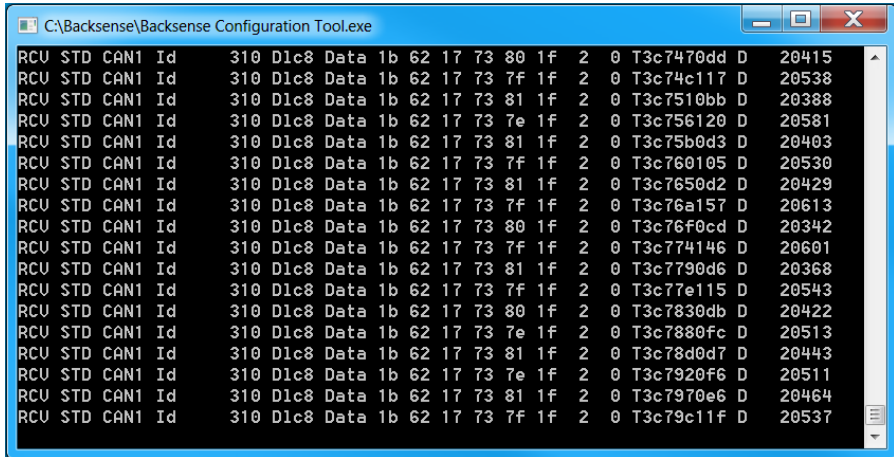

7.6.13 The Backsense Configuration Tool must be closed in order to return to the Backsense CAN Radar Test Tool.

7.7 System Errors

In the event of system error, loss of CAN data from one or more sensors may occur. The user should verify conditions below before suspecting a faulty sensor

- Sensor or extension cable not connected.
Action: Check all connectors are plugged together fully.
- No data connection between sensor and host.
Action: Check for damage on connectors and cables.
- No power connection to sensor.
Action: Check for damage on connectors and cable.
- CAN communication error with sensor.
Cable is routed or system is installed too close to an electric noise source in vehicle.
Action: Try to relocate affected part of the system.

The Brigade Backsense® System cannot self-diagnose potential sensor detection issues caused by the build-up of ice, dirt, mud, heavy rain or immersion in water, which may impede system performance. Therefore, follow section “8 Testing and Maintenance”.

8 Testing and Maintenance

8.1 Operator Instructions

This information is addressed to the operator of the vehicle where a Brigade Backsense® System is installed:

- 1) The Brigade Backsense® is intended as an Object Detection System and should not be relied upon as your primary defence for the safe operation of the vehicle. It is an aid to contribute in conjunction with other established safety programs and procedures to ensure safe operation of the vehicle in relation to surrounding persons and objects. Drivers and operators should not attempt to reconfigure the Backsense® detection area and this should be strictly done by technically trained operators when the vehicle is stationary.
- 2) Testing and inspection of the system should be carried out in accordance with this manual. The driver or operator is responsible for ensuring the Brigade Backsense® System is working as intended.
- 3) Operators using this equipment are strongly recommended to check the system's proper operation at the beginning of every shift. If this is not possible the system should be assumed as faulty until this can be done.
- 4) Improved safety depends on the proper function of this product in conformance with these instructions. Additional safety can be achieved when the Brigade Backsense® System is used in conjunction with Brigade's camera-monitor systems. This may allow triggering camera views and providing additional vehicle information during manoeuvring. It is necessary to read, understand and follow all instructions received with the Brigade Backsense® System.
- 5) The Brigade Backsense® System for object detection is intended for use on commercial vehicles and machinery equipment. Correct installation of the system requires a good understanding of vehicle electrical systems and procedures along with proficiency in installation.
- 6) Keep these instructions in a safe place and refer to them when maintaining and / or reinstalling the product.

8.2 Maintenance and Testing

This information is addressed to the operator for maintenance and testing of a vehicle with the Brigade Backsense® System installed. This is also to familiarise the operator with the detection area and behaviour of the system. More frequent inspections should be performed in cases where:

- The vehicle is operating in a particularly dirty or harsh environment.
- The operator has reason to suspect the system is not working or has been damaged.

Procedure:

- 1) Clean the sensor housing of any accumulation of dirt, mud, snow, ice or any other debris.
- 2) Visually inspect the sensor or sensors where multiple sensors are installed and verify that they are securely attached to the vehicle and are not damaged.
- 3) Visually inspect the system's cables as well as possible and verify that they are properly secured and not damaged.
- 4) The location of the test should ensure the area in front of the sensor or sensors where multiple sensors are installed are clear of obstacles and larger than the detection range of the installed Brigade Backsense® System.

If any of the following tests fail, follow the Hardware Installation instructions in section 4 and fault finding guidance in section 7.7 or contact Brigade technical support if still in doubt.

For the following tests, the operator requires objects to be placed in the sensor's detection areas or an assistant (to observe the host activity).

- 5) Verify each accuracy of detection distance: Starting from the outside of the detection area, the operator should check several points along the centre line of the detection width down to around 0.4m distance from each sensor. The operator should note down the distance at which host system functions occur and verify that these are in line with the system configuration for this vehicle.
- 6) Close detection behaviour: Verify objects in between 0.3m and 1.3m distance are only detected if they move relative to that sensor.
- 7) Very close detection awareness: Verify objects less than 0.3m from each sensor are not detected.
- 8) Similar to the previous tests the operator should scan all the edges of the detection area according to the installed system or configuration for this vehicle. They should note down the detected locations and check if they match with the detection area set when this Brigade Backsense® System was installed on this vehicle.
- 9) During the test the operator should verify that each detection zone LED on the Backsense display is illuminated, this will ensure the correct distance of the detected object is indicated to the driver.

9 Specifications

Operation Characteristics

Model name	BS-9000
Detection length	30m (98 ft approx.)
Detection width	10m (33ft approx.)
Nominal tolerance	±0.25m / (1ft approx.)
Radar beam angle	Horizontal 120° out to the maximum designated width Vertical 12° (symmetrically perpendicular to sensor front surface)
Distance resolution	0.25m (1ft approx.). Limitations apply, see section "1.2 Object Detection Capability" for details.
Object detection	≤ 0.5second. Limitations apply, see section "1.2 Object Detection Capability" for details.
Power on to system ready	≤ 2.5 seconds
Maximum simultaneous objects per sensor	8
Maximum sensors per system	8

Communication between Sensor and Host

Physical layer	CAN bus 2.0A Base Frame Format
Protocol layer	Proprietary Protocol (see section 5 for details)
Max. cable length between termination points	30m (98ft approx.)

Sensor Specifications

Transmitter	Frequency Modulated Continuous Wave (FMCW)
Frequency and bandwidth	24.05GHz to 24.25GHz
Dimensions (all in mm)	217 x 129 x 50
Connector	Manufacturer Deutsch Part Number DT06-4S-CE06 (female)
Cable length	1.0m / 3ft 3in
Weight	0.7kg (including pigtail cable)
Operating temperature	-40°C to +85°C
IP protection	Sensor: IP69K (Protected from dust & strong water jets) Connector: IP68 (Protected from dust & immersion into water)
Vibration	8.3G
Shock	100G all three axes
Mounting	Four 5.2mm diameter holes on 198mm horizontal centres, and 40mm vertical centres. Unit is supplied with M5x30mm screws and M5 polymer locknuts for mounting purposes. Recommended torque is 5.6Nm, (50 inch/lbs approx.).
Bracket	Optional, adjustable for vertical angle. See section 2.2

Electrical Specification

Input Voltage Range	9 to 32 Vdc
Input Current (per sensor)	typ. 0.31A at 12Vdc / typ. 0.17A at 24Vdc
Power Supply Fusing	Dependent upon number of sensors in network. See section 4.9 for details
Vehicle Connections	System supply positive & negative.
Host Connections	CAN High & CAN Low
Voltage Protection	ISO 16750 (over and reverse voltage protection)

Approvals

CE

ECE Regulation No. 10 Revision 4 ("E-marking")

ISO 16750

ISO 13766

EN 13309

FCC

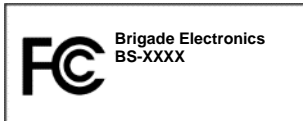

This device complies with part 15 of the FCC Rules. Operation is subject to the following two conditions: (1) This device may not cause harmful interference, and (2) this device must accept any interference received, including interference that may cause undesired operation.

Any change or modifications not expressly approved by the responsible party responsible for compliance could void the user's authority to operate the equipment.

EU Declaration of Conformity

Product Types:

Brigade Backsense Radar Obstacle Detection System BS-9000

Manufacturer:

Brigade House, The Mills, Station Road, South Darenth, DA4 9BD, UK

This declaration of conformity is issued under the sole responsibility of Brigade Electronics.

Objects of the declaration:

Radar sensor, cables and termination

The objects of the declaration described above are in conformity with the relevant Union harmonisation legislation: Directive 2014/53/EU

Relevant Harmonised Standards:

- EN301489-1 V2.1.1(2017-02) and EN301489-3 V2.1.0 (2017-03)
- EN300440-2 V1.4.1(2010-08) and EN300440-1 V2.1.1(2017-03)

Additional information:

- Operational Frequency Band: 24050MHz – 24250MHz
- Maximum Transmitted Power: 19.20 dBm
- This equipment should be installed and operated with a minimum distance of 20cm between the radar sensor and any human body.

Signed for and on behalf of Brigade Electronics Group PLC

11/01/2018, South Darenth, DA4 9BD, UK

David Wallin, Quality and Standards Manager

A handwritten signature in black ink, appearing to read 'David Wallin', is written over the printed name.

10

Mounting Dimensions

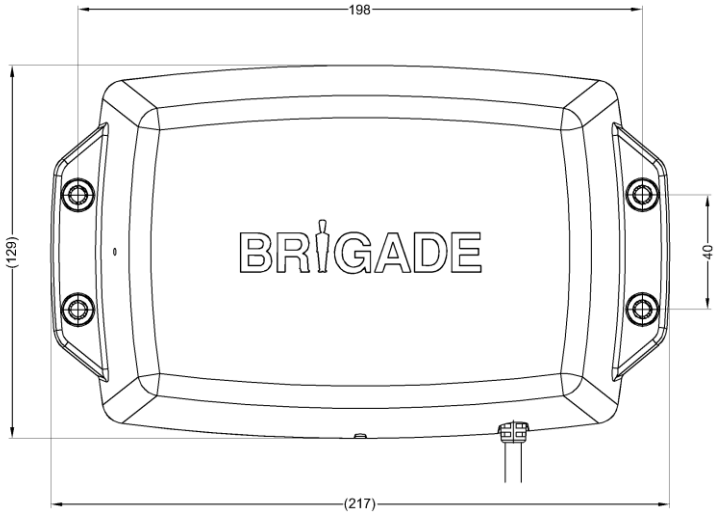

Disclaimer

Radar obstacle detection systems are an invaluable driver aid but do not exempt the driver from taking every normal precaution when conducting a manoeuvre. No liability arising out of the use or failure of the product can in any way be attached to Brigade or to the distributor.

Avvertissement

Les systèmes de radar à détection d'obstacle sont une aide précieuse pour le conducteur, mais celui-ci doit toutefois prendre toutes les précautions nécessaires pendant les manœuvres. Brigade ou ses distributeurs n'assument aucune responsabilité résultant de l'utilisation ou d'un défaut du produit.

Haftungsausschluss

Radar basierte Hinderniserkennungssysteme sind für den Fahrer eine unschätzbare Hilfe, ersetzen aber beim Manövrieren keinesfalls die üblichen Vorsichtsmaßnahmen. Für Schäden aufgrund der Verwendung oder eines Defekts dieses Produkts übernehmen Brigade oder der Vertriebshändler keinerlei Haftung.

Condizioni di utilizzo

I sistemi di rilevamento ostacoli radar costituiscono un prezioso ausilio alla guida, ma il conducente deve comunque assicurarsi di prendere tutte le normali precauzioni quando esegue una manovra. Né Brigade né il suo distributore saranno responsabili per eventuali danni di qualsiasi natura causati dall'utilizzo o dal mancato utilizzo del prodotto.

Uwaga

Radarowe systemy wykrywania przeszkód stanowią nieocenione wsparcie dla kierowców i operatorów, ale ich posiadanie nie zwalnia użytkowników z zachowania środków szczególnej ostrożności podczas prowadzenia i wykonywania manewrów. Brigade oraz dystrybutorzy produktów nie mogą ponieść żadnej odpowiedzialności prawnej wynikającej ze skutków użytkowania lub awarii produktu.

Aviso legal

Undue los system's de detección de obstáculos por radar constituyen una valiosa ayuda, no eximen al conductor de tomar todas las precauciones normales al hacer una maniobra. Brigade y sus distribuidores comerciales no se responsabilizan de cualquier daño derivado del uso o de un mal funcionamiento del producto.

Declinação de responsabilidade

Os sistemas radar de detecção de obstáculo são uma ajuda incalculável ao motorista, mas não dispensam o motorista de tomar todas as precauções normais ao realizar uma manobra. Nenhuma responsabilidade decorrente do uso ou falha do produto pode de forma alguma ser atribuída ao Brigade ou ao distribuidor.

Verwerping

Radar obstakel detectiesystemen zijn een waardevolle hulp voor de bestuurder, maar ontheffen hem echter niet van de verplichting om het voertuig zorgvuldig te manoeuvreren. Brigade en zijn distributeurs zijn niet aansprakelijk voor schade door gebruik of het niet functioneren van het product.

Ограничение ответственности

Радарные системы обнаружения препятствий является дополнительным средством помощи водителю, но не освобождает от соблюдения водителем всех необходимых мер предосторожности при совершении маневров. Brigade Electronics или распространители продукции не несут ответственности вытекающей из невозможности эксплуатации или неисправности продукции.

Hatırlatma

Radar Objе Algılama Sistemleri sürücünün önemli bir yardımcısı olmakla birlikte, manevra esnasında sürücü bir kaza olmaması için her türlü önlemi almalıdır. Brigade veya bölgesel dağıtıcıları yapılacak yanlış bir uygulama ve sonucunda oluşabilecek maddi ve/veya manevi kayıplardan sorumlu tutulamaz.

Specifications subject to change. Sous réserve de modifications techniques. Änderungen der technischen Daten vorbehalten. Specifiche soggette a variazioni. Las especificaciones están sujetas a cambios. Wijzigingen in specificaties voorbehouden. As especificações estão sujeitas a alterações. Спецификация может изменяться. Спецификация techniczna może ulec zmianie. Özellikler haber vermeksizin değiştirilebilir.

Serial No:	Part No:
------------	----------



www.brigade-electronics.com

